

IP65, class I

V LUM

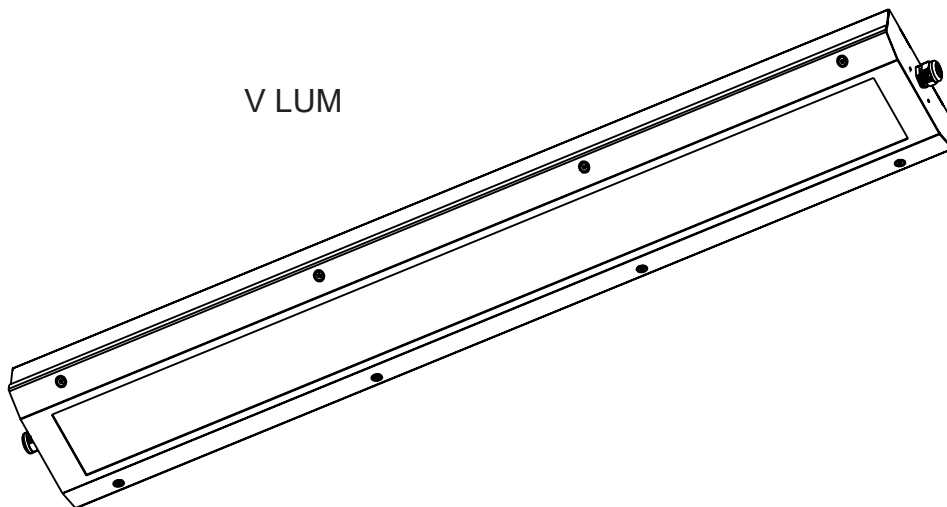

Luminaire dimensions:

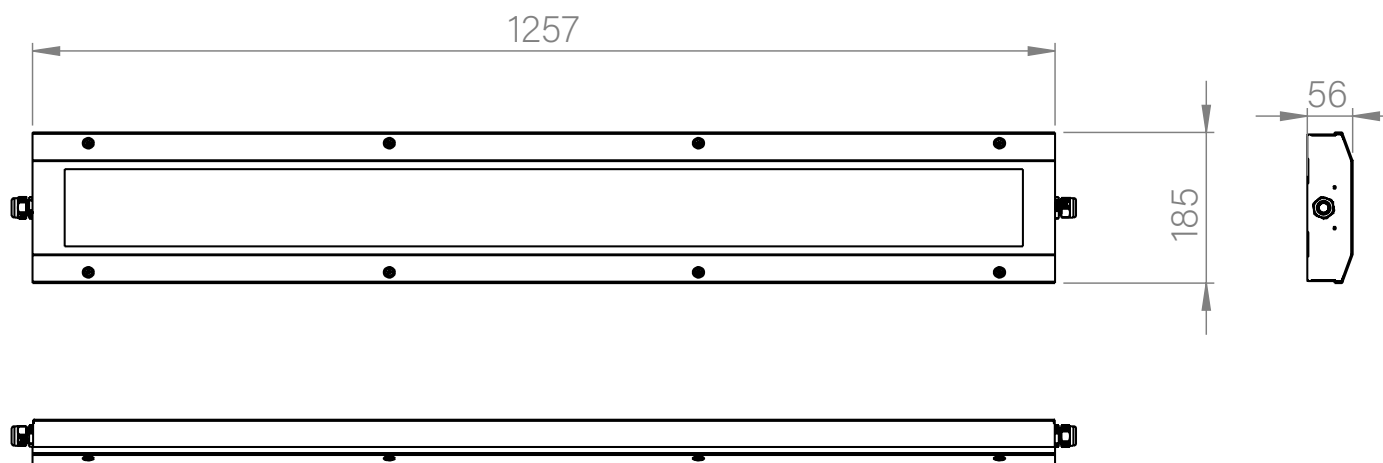

Distance of mounting holes $\varnothing 6,3$:

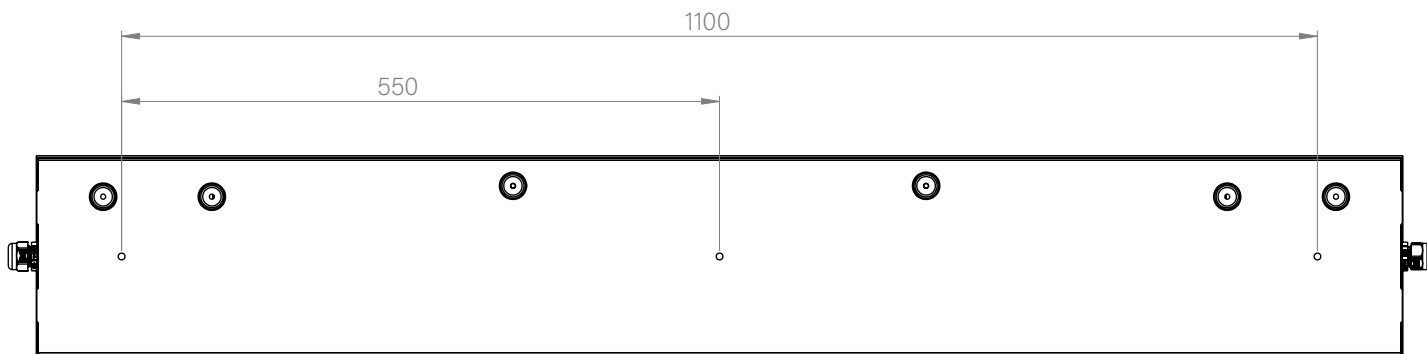

Technical data:

The technical data are mentioned on the label of the lighting fixture. (ambient temperature, IP degree, etc.).

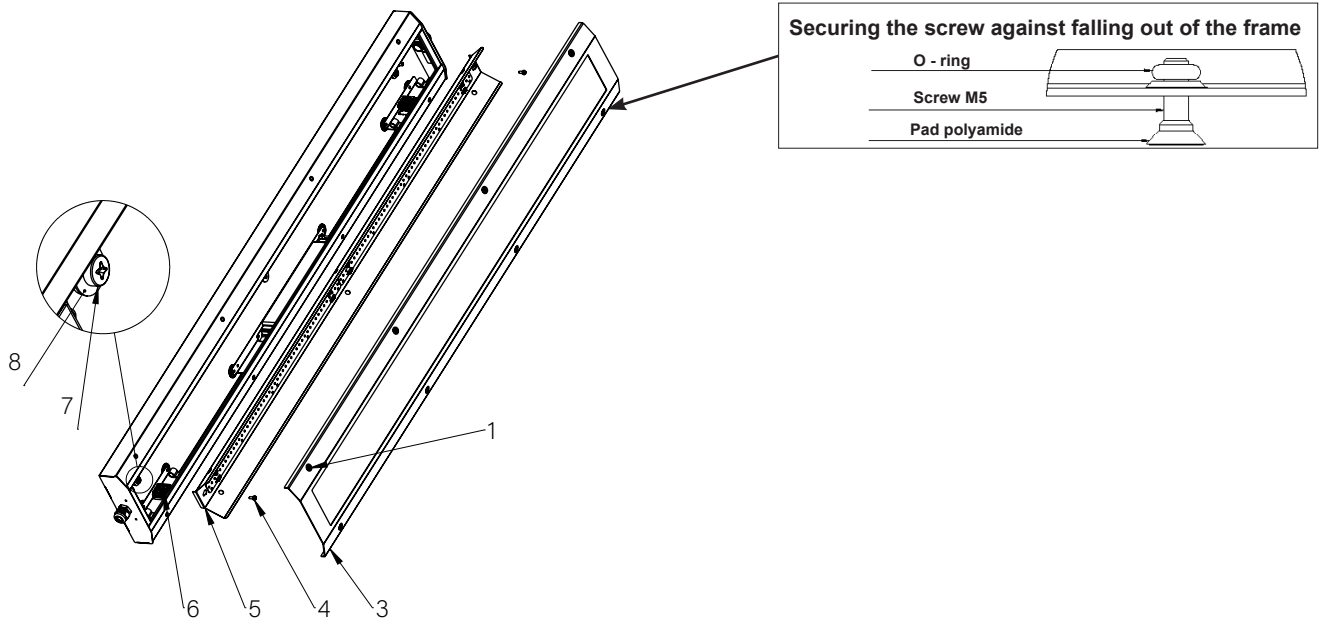

Securing the screw against falling out of the frame

O - ring

Screw M5

Pad polyamide

Mounting:

1. Unscrew the screws (1), which are fixing cover (3), but do not take out the screws, because sealing can fall off and remove the cover (3).
2. Unscrew the screws (4), which are holding reflector (5) and remove the reflector. **Do not touch LED III**
3. Fix the luminaire by screws (5).
4. Do not forget sealing washer (8). screws (7) are not part of the product. Screws M6 are recommended.

Clip	V LUM			
L1	phase conductor			
L2	-			
L3	-			
N	neutral conductor			
⊕	protecting conductor			

L1 ⊕ N

L2 L3

8-9 mm

0,5- 2,5 mm²

*The marking and connection of individual terminals may differ depending on the required lighting fixture equipment.

5. Pull the power cable through the cable gland. Tighten bushings to a state of partial deformation of the rubber sealing washers, tightening torque 2,5Nm
Supply cable must have an outer diameter in the range 6 - 13mm.
6. Connect conductors to terminat block (6).
7. Insert reflectors (5) and secure with screws (4). Tightening torque 2Nm.
8. Close Luminer using cover (3).
9. Push the cover (3) for the compression of the seal and screw up (1). Tightening torque 4Nm. Danger overtightening the screw !



The luminaire must be connected to the mains only by a person with corresponding qualification pursuant to applicable regulations on professional competence in electrical engineering.
When installing the luminaire, electrostatic discharge safety measures must be observed by using suitable tools!
Non-compliance with the installation instructions will result in a loss of the manufacturer's liability for any damage!
 The light source in this luminaire is non-replaceable.
 The luminaire does not require any special maintenance. Clean a soiled luminaire with lukewarm water and detergent.



ATTENTION!!!
 For wall installation of lighting fixture must be LED driver positioned facing downwards
WARNING – potential danger of electrostatic charging.
WARNING – the lighting fixture must be installed in the position, which does not allow the touch of persons and parts of the fixture.
WARNING – the lighting for fixed installation.
WARNING – the fixture should be cleaned with damp duster only. It is necessary to keep periodic cleaning intervals of lighting fixture.
WARNING – do not open under voltage.
WARNING – replace protective cover.



The manufacturer is engaged in the Waste from Electrical and Electronic Equipment collection system according to applicable regulations and in a packaging collection and recycling system of the EKO-KOM company (EK-F06070058).